



Series #CDBA/S

SET~3

रोल नं.					
Roll No.					

प्रश्न-पत्र कोड
Q.P. Code **30/S/3**

परीक्षार्थी प्रश्न-पत्र कोड को उत्तर-पुस्तिका के मुख-पृष्ठ पर अवश्य लिखें ।
Candidates must write the Q.P. Code on the title page of the answer-book.

नोट / NOTE :

- (i) कृपया जाँच कर लें कि इस प्रश्न-पत्र में मुद्रित पृष्ठ 27 हैं ।
Please check that this question paper contains 27 printed pages.
- (ii) कृपया जाँच कर लें कि इस प्रश्न-पत्र में 38 प्रश्न हैं ।
Please check that this question paper contains 38 questions.
- (iii) प्रश्न-पत्र में दाहिने हाथ की ओर दिए गए प्रश्न-पत्र कोड को परीक्षार्थी उत्तर-पुस्तिका के मुख-पृष्ठ पर लिखें ।
Q.P. Code given on the right hand side of the question paper should be written on the title page of the answer-book by the candidate.
- (iv) कृपया प्रश्न का उत्तर लिखना शुरू करने से पहले, उत्तर-पुस्तिका में प्रश्न का क्रमांक अवश्य लिखें ।
Please write down the serial number of the question in the answer-book before attempting it.
- (v) इस प्रश्न-पत्र को पढ़ने के लिए 15 मिनट का समय दिया गया है । प्रश्न-पत्र का वितरण पूर्वाह्न में 10.15 बजे किया जाएगा । 10.15 बजे से 10.30 बजे तक छात्र केवल प्रश्न-पत्र को पढ़ेंगे और इस अवधि के दौरान वे उत्तर-पुस्तिका पर कोई उत्तर नहीं लिखेंगे ।
15 minute time has been allotted to read this question paper. The question paper will be distributed at 10.15 a.m. From 10.15 a.m. to 10.30 a.m., the students will read the question paper only and will not write any answer on the answer-book during this period.

गणित (मानक)
MATHEMATICS (STANDARD)



निर्धारित समय : 3 घण्टे

अधिकतम अंक : 80

Time allowed : 3 hours

Maximum Marks : 80



सामान्य निर्देश :

निम्नलिखित निर्देशों को बहुत सावधानी से पढ़िए और उनका सख्ती से पालन कीजिए :

- (i) इस प्रश्न-पत्र में 38 प्रश्न हैं। सभी प्रश्न अनिवार्य हैं।
- (ii) यह प्रश्न-पत्र पाँच खण्डों में विभाजित है – क, ख, ग, घ एवं ङ।
- (iii) खण्ड क में प्रश्न संख्या 1 से 18 तक बहुविकल्पीय (MCQ) तथा प्रश्न संख्या 19 एवं 20 अभिकथन एवं तर्क आधारित 1 अंक के प्रश्न हैं।
- (iv) खण्ड ख में प्रश्न संख्या 21 से 25 तक अति लघु-उत्तरीय (VSA) प्रकार के 2 अंकों के प्रश्न हैं।
- (v) खण्ड ग में प्रश्न संख्या 26 से 31 तक लघु-उत्तरीय (SA) प्रकार के 3 अंकों के प्रश्न हैं।
- (vi) खण्ड घ में प्रश्न संख्या 32 से 35 तक दीर्घ-उत्तरीय (LA) प्रकार के 5 अंकों के प्रश्न हैं।
- (vii) खण्ड ङ में प्रश्न संख्या 36 से 38 तक प्रकरण अध्ययन आधारित 4 अंकों के प्रश्न हैं। प्रत्येक प्रकरण अध्ययन में आंतरिक विकल्प 2 अंकों के प्रश्न में दिया गया है।
- (viii) प्रश्न-पत्र में समग्र विकल्प नहीं दिया गया है। यद्यपि, खण्ड ख के 2 प्रश्नों में, खण्ड ग के 2 प्रश्नों में, खण्ड घ के 2 प्रश्नों में तथा खण्ड ङ के 3 प्रश्नों में आंतरिक विकल्प का प्रावधान दिया गया है।
- (ix) जहाँ आवश्यक हो स्वच्छ आकृतियाँ बनाइए। जहाँ आवश्यक हो $\pi = \frac{22}{7}$ लीजिए, यदि अन्यथा न दिया गया हो।
- (x) कैल्कुलेटर का उपयोग वर्जित है।

खण्ड क

इस खण्ड में बहुविकल्पीय प्रश्न (MCQ) हैं, जिनमें प्रत्येक प्रश्न 1 अंक का है।

20×1=20

1. यदि एक खंभे की भूमि पर छाया की लंबाई, खंभे की ऊँचाई का $\sqrt{3}$ गुना है, तो सूर्य का उन्नतांश है :
(A) 30° (B) 45°
(C) 60° (D) 90°
2. दो पासों को एक साथ उछाला गया तथा उन पर आई संख्याओं का गुणनफल नोट किया गया। दोनों पासों पर आई संख्याओं का गुणनफल 8 और 13 के बीच होने की प्रायिकता है :
(A) $\frac{7}{36}$ (B) $\frac{5}{36}$
(C) $\frac{2}{9}$ (D) $\frac{1}{4}$





General Instructions :

Read the following instructions very carefully and strictly follow them :

- (i) This question paper contains **38** questions. **All** questions are **compulsory**.
- (ii) This question paper is divided into **five** Sections – **A, B, C, D** and **E**.
- (iii) In **Section A**, Questions no. **1** to **18** are multiple choice questions (MCQs) and questions number **19** and **20** are Assertion-Reason based questions of **1** mark each.
- (iv) In **Section B**, Questions no. **21** to **25** are very short answer (VSA) type questions, carrying **2** marks each.
- (v) In **Section C**, Questions no. **26** to **31** are short answer (SA) type questions, carrying **3** marks each.
- (vi) In **Section D**, Questions no. **32** to **35** are long answer (LA) type questions carrying **5** marks each.
- (vii) In **Section E**, Questions no. **36** to **38** are case study based questions carrying **4** marks each. Internal choice is provided in **2** marks questions in each case study.
- (viii) There is no overall choice. However, an internal choice has been provided in **2** questions in Section B, **2** questions in Section C, **2** questions in Section D and **3** questions in Section E.
- (ix) Draw neat diagrams wherever required. Take $\pi = \frac{22}{7}$ wherever required, if not stated.
- (x) Use of calculator is **not** allowed.

SECTION A

This section comprises Multiple Choice Questions (MCQs) of 1 mark each.

20×1=20

1. If the length of the shadow on the ground of a pole is $\sqrt{3}$ times the height of the pole, then the angle of elevation of the Sun is :
(A) 30° (B) 45°
(C) 60° (D) 90°
2. Two dice are thrown at the same time and the product of the numbers appearing on them is noted. The probability that the product of the numbers lies between 8 and 13 is :
(A) $\frac{7}{36}$ (B) $\frac{5}{36}$
(C) $\frac{2}{9}$ (D) $\frac{1}{4}$





3. यदि समीकरणों $x + py = 6$ और $x = 15$ के ज्यामितीय निरूपण से बनने वाली दो सरल रेखाओं का प्रतिच्छेदन बिंदु $(k, 3)$ है, तो (k, p) है :
- (A) $(15, 3)$ (B) $(15, -3)$
(C) $(3, 15)$ (D) $(-15, 3)$
4. x -अक्ष का वह बिंदु, जो बिंदुओं $(5, -3)$ और $(4, 2)$ से एकसमान दूरी पर है, है :
- (A) $(4.5, 0)$ (B) $(7, 0)$
(C) $(0.5, 0)$ (D) $(-7, 0)$
5. यदि $x = 5$, द्विघात समीकरण $2x^2 + (k - 1)x + 10 = 0$ का एक हल है, तो k का मान है :
- (A) 11 (B) -11
(C) 13 (D) -13
6. ΔXYZ में, $XY = 6$ cm है। यदि XY और XZ पर क्रमशः दो बिंदु M तथा N हैं जिससे $MN \parallel YZ$ और $XN = \frac{1}{4}XZ$, तो XM की लंबाई है :

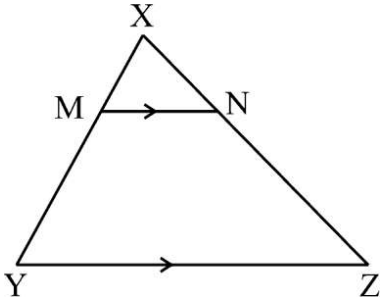

- (A) 1.2 cm (B) 1.5 cm
(C) 2 cm (D) 4 cm
7. दो धनात्मक पूर्णाकों m और n को $m = p^5q^2$ तथा $n = p^3q^4$, जहाँ p और q अभाज्य संख्याएँ हैं, द्वारा व्यक्त किया गया है। m और n का LCM है :
- (A) p^8q^6 (B) p^3q^2
(C) p^5q^4 (D) $p^5q^2 + p^3q^4$



3. If $(k, 3)$ is the point of intersection of the lines represented by $x + py = 6$ and $x = 15$, then (k, p) will be :
- (A) $(15, 3)$ (B) $(15, -3)$
(C) $(3, 15)$ (D) $(-15, 3)$
4. The point on x-axis which is equidistant from the points $(5, -3)$ and $(4, 2)$ is :
- (A) $(4.5, 0)$ (B) $(7, 0)$
(C) $(0.5, 0)$ (D) $(-7, 0)$
5. If $x = 5$ is a solution of the quadratic equation $2x^2 + (k - 1)x + 10 = 0$, then the value of k is :
- (A) 11 (B) -11
(C) 13 (D) -13
6. In $\triangle XYZ$, $XY = 6$ cm. If M and N are two points on XY and XZ respectively such that $MN \parallel YZ$ and $XN = \frac{1}{4}XZ$, then the length of XM is :

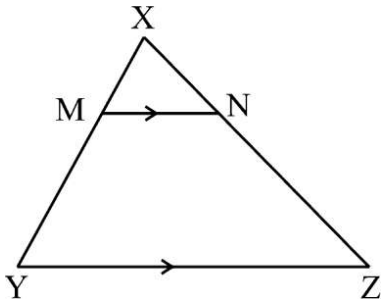

- (A) 1.2 cm (B) 1.5 cm
(C) 2 cm (D) 4 cm
7. Two positive integers m and n are expressed as $m = p^5q^2$ and $n = p^3q^4$, where p and q are prime numbers. The LCM of m and n is :
- (A) p^8q^6 (B) p^3q^2
(C) p^5q^4 (D) $p^5q^2 + p^3q^4$





8. बिंदुओं $P(-5, 11)$ और Q को मिलाने वाला रेखाखंड, बिंदु $M(2, -3)$ से इस प्रकार अन्तः विभाजित होता है कि $PM : MQ = 7 : 2$. बिंदु Q के निर्देशांक हैं :
- (A) $(4, -7)$ (B) $(27.5, -52)$
(C) $(-7, 4)$ (D) $\left(\frac{4}{9}, \frac{1}{9}\right)$
9. यदि $k + 7$, $2k - 2$ और $2k + 6$ एक A.P. के तीन क्रमागत पद हैं, तो k का मान है :
- (A) 15 (B) 17
(C) 5 (D) 1
10. एक समचतुर्भुज ABCD के विकर्ण बिंदु O पर प्रतिच्छेदी हैं। बिंदु 'O' को केंद्र लेकर, त्रिज्या 6 cm की एक चाप OA तथा OD को क्रमशः बिंदुओं E और F पर काटती है। त्रिज्यखंड OEF का क्षेत्रफल है :
- (A) $9\pi \text{ cm}^2$ (B) $3\pi \text{ cm}^2$
(C) $12\pi \text{ cm}^2$ (D) $18\pi \text{ cm}^2$
11. दो A.P. के पहले पद एकसमान हैं। पहले A.P. का सार्व अंतर -3 है और दूसरे A.P. का सार्व अंतर -5 है। दूसरे A.P. के 6वें पद का पहले A.P. के 6वें पद से अंतर है :
- (A) 2 (B) -8
(C) -10 (D) 10
12. 600 आइसक्रीमों के समूह में से एक चॉकलेट फ्लेवर वाली आइसक्रीम के निकालने की प्रायिकता 0.055 है। इस समूह में चॉकलेट फ्लेवर वाली आइसक्रीमों की संख्या है :
- (A) 33 (B) 55
(C) 11 (D) 44





8. A line segment joining the points $P(-5, 11)$ and Q is divided internally by the point $M(2, -3)$ such that $PM : MQ = 7 : 2$. The coordinates of Q are :
- (A) $(4, -7)$ (B) $(27.5, -52)$
(C) $(-7, 4)$ (D) $\left(\frac{4}{9}, \frac{1}{9}\right)$
9. If $k + 7$, $2k - 2$ and $2k + 6$ are three consecutive terms of an A.P., then the value of k is :
- (A) 15 (B) 17
(C) 5 (D) 1
10. The diagonals of a rhombus $ABCD$ intersect at O . Taking 'O' as the centre, an arc of radius 6 cm is drawn intersecting OA and OD at E and F respectively. The area of the sector OEF is :
- (A) $9\pi \text{ cm}^2$ (B) $3\pi \text{ cm}^2$
(C) $12\pi \text{ cm}^2$ (D) $18\pi \text{ cm}^2$
11. Two A.P.s have the same first term. The common difference of the first A.P. is -3 and of the second A.P. is -5 . The difference of the 6th term of the second A.P. from that of the first A.P. is :
- (A) 2 (B) -8
(C) -10 (D) 10
12. The probability of getting a chocolate flavoured ice cream at random, in a lot of 600 ice creams is 0.055. The number of chocolate flavoured ice creams in the lot is :
- (A) 33 (B) 55
(C) 11 (D) 44





13. दी गई आकृति में, केंद्र O वाले एक वृत्त पर PA और PB दो स्पर्श-रेखाएँ खींची गई हैं और वृत्त की त्रिज्या 5 cm है। यदि $\angle APB = 60^\circ$ है, तो PA की लंबाई है :

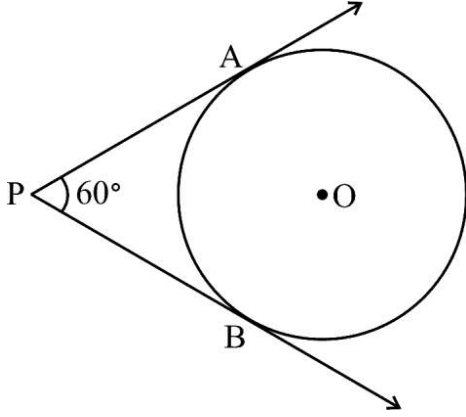

- (A) $\frac{5}{\sqrt{3}}$ cm (B) $5\sqrt{3}$ cm
(C) $\frac{10}{\sqrt{3}}$ cm (D) 10 cm
14. यदि $5 \tan \theta = 2$ है, तो $\frac{10 \sin \theta - 2 \cos \theta}{5 \sin \theta + 3 \cos \theta}$ का मान है :
- (A) $\frac{2}{5}$ (B) $\frac{5}{2}$
(C) 1 (D) $\frac{46}{31}$
15. 52 पत्तों की एक ताश की गड्डी से सभी बेगम, गुलाम और इक्के निकाल दिए जाते हैं। शेष पत्तों को अच्छी प्रकार से फेंटा जाता है और तब एक पत्ता यादृच्छया निकाला जाता है। निकाले गए पत्ते के एक बादशाह होने की प्रायिकता है :
- (A) $\frac{1}{10}$ (B) $\frac{1}{13}$
(C) $\frac{3}{10}$ (D) $\frac{3}{13}$
16. यदि व्यास 14 cm वाले एक वृत्त का एक त्रिज्यखंड केन्द्र पर 90° का कोण बनाता है, तो त्रिज्यखंड का परिमाण है :
- (A) 25 cm (B) 11 cm
(C) 36 cm (D) 22 cm





13. In the given figure, PA and PB are two tangents drawn to the circle with centre O and radius 5 cm. If $\angle APB = 60^\circ$, then the length of PA is :

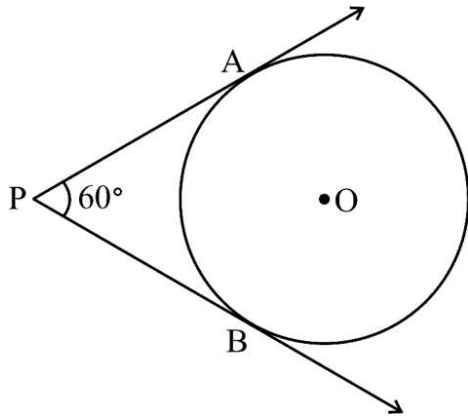

- (A) $\frac{5}{\sqrt{3}}$ cm (B) $5\sqrt{3}$ cm
(C) $\frac{10}{\sqrt{3}}$ cm (D) 10 cm
14. If $5 \tan \theta = 2$, then the value of $\frac{10 \sin \theta - 2 \cos \theta}{5 \sin \theta + 3 \cos \theta}$ is :
- (A) $\frac{2}{5}$ (B) $\frac{5}{2}$
(C) 1 (D) $\frac{46}{31}$
15. All queens, jacks and aces are removed from a pack of 52 playing cards. The remaining cards are well-shuffled and one card is picked up at random from it. The probability of that card to be a king is :
- (A) $\frac{1}{10}$ (B) $\frac{1}{13}$
(C) $\frac{3}{10}$ (D) $\frac{3}{13}$
16. If the sector of a circle with diameter 14 cm makes an angle 90° at the centre, then the perimeter of the sector is :
- (A) 25 cm (B) 11 cm
(C) 36 cm (D) 22 cm





17. $\left(\sin^2 \theta + \frac{1}{1 + \tan^2 \theta} \right)$ का मान है :

- (A) 0 (B) 2
(C) 1 (D) -1

18. एक टोपी बेलनाकार आकार की है जिस पर एक शंकु अध्यारोपित है। यदि बेलनाकार भाग का आयतन शंक्वाकार भाग के आयतन के बराबर है, तो बेलनाकार भाग की ऊँचाई का शंक्वाकार भाग की ऊँचाई से अनुपात है :

- (A) 1 : 2 (B) 1 : 3
(C) 2 : 1 (D) 3 : 1

प्रश्न संख्या 19 और 20 अभिकथन एवं तर्क आधारित प्रश्न हैं। दो कथन दिए गए हैं जिनमें एक को अभिकथन (A) तथा दूसरे को तर्क (R) द्वारा अंकित किया गया है। इन प्रश्नों के सही उत्तर नीचे दिए गए कोडों (A), (B), (C) और (D) में से चुनकर दीजिए।

- (A) अभिकथन (A) और तर्क (R) दोनों सही हैं और तर्क (R), अभिकथन (A) की सही व्याख्या करता है।
(B) अभिकथन (A) और तर्क (R) दोनों सही हैं, परन्तु तर्क (R), अभिकथन (A) की सही व्याख्या नहीं करता है।
(C) अभिकथन (A) सही है, परन्तु तर्क (R) गलत है।
(D) अभिकथन (A) गलत है, परन्तु तर्क (R) सही है।

19. अभिकथन (A) : यदि एक बहुपद का ग्राफ x-अक्ष को केवल दो बिंदुओं पर प्रतिच्छेदित करता हो, तो बहुपद के शून्यकों की संख्या 2 है।

तर्क (R) : एक बहुपद के शून्यकों की संख्या उन बिंदुओं की संख्या के बराबर होती है जिन पर बहुपद का ग्राफ x-अक्ष को प्रतिच्छेदित करता है।





17. The value of $\left(\sin^2 \theta + \frac{1}{1 + \tan^2 \theta} \right)$ is :

- (A) 0 (B) 2
(C) 1 (D) -1

18. A cap is cylindrical in shape, surmounted by a conical top. If the volume of the cylindrical part is equal to that of the conical part, then the ratio of the height of the cylindrical part to the height of the conical part is :

- (A) 1 : 2 (B) 1 : 3
(C) 2 : 1 (D) 3 : 1

Questions number 19 and 20 are Assertion and Reason based questions. Two statements are given, one labelled as Assertion (A) and the other is labelled as Reason (R). Select the correct answer to these questions from the codes (A), (B), (C) and (D) as given below.

- (A) Both Assertion (A) and Reason (R) are true and Reason (R) is the correct explanation of the Assertion (A).
(B) Both Assertion (A) and Reason (R) are true, but Reason (R) is **not** the correct explanation of the Assertion (A).
(C) Assertion (A) is true, but Reason (R) is false.
(D) Assertion (A) is false, but Reason (R) is true.

19. *Assertion (A)* : If the graph of a polynomial intersects the x-axis at exactly two points, then the number of zeroes of that polynomial is 2.

Reason (R) : The number of zeroes of a polynomial is equal to the number of points where the graph of the polynomial intersects x-axis.





20. अभिकथन (A) : बाह्य बिंदु T से केंद्र 'O' वाले वृत्त पर खींची गई दो स्पर्श-रेखाएँ TA और TB हैं। यदि $\angle TBA = 75^\circ$ है, तो $\angle ABO = 25^\circ$ होगा।

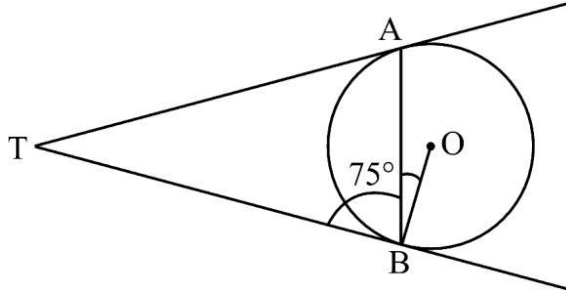

तर्क (R) : वृत्त के किसी बिंदु पर खींची गई स्पर्श-रेखा स्पर्श बिंदु से जाने वाली त्रिज्या पर लंब होती है।

खण्ड ख

इस खण्ड में अति लघु-उत्तरीय (VSA) प्रकार के प्रश्न हैं, जिनमें प्रत्येक के 2 अंक हैं।

5×2=10

21. (a) 14 cm त्रिज्या वाले एक वृत्त की कोई जीवा केंद्र पर 90° का कोण अंतरित करती है। संगत लघु वृत्तखण्ड का क्षेत्रफल ज्ञात कीजिए।

अथवा

- (b) आकृति में छायांकित क्षेत्र का क्षेत्रफल ज्ञात कीजिए, यदि प्रत्येक वृत्त की त्रिज्या 7 cm है और प्रत्येक वृत्त दो अन्य वृत्तों को बाह्य रूप से स्पर्श करता हो।

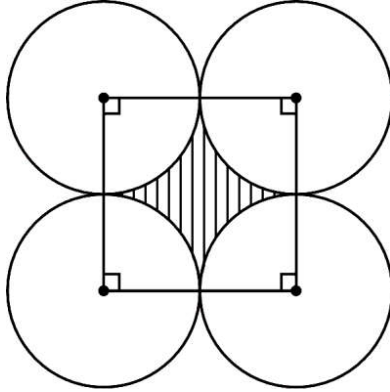

22. जाँच कीजिए कि क्या 'n' का कोई ऐसा प्राकृत संख्या वाला मान है, जिसके लिए $(14)^n$ अंक '0' या '5' पर समाप्त होता है।

23. (a) यदि $\cos(A + B) = \frac{1}{2}$ और $\tan(A - B) = \frac{1}{\sqrt{3}}$ है, जहाँ $0 \leq A + B \leq 90^\circ$ है, तो $\sec(2A - 3B)$ का मान ज्ञात कीजिए।

अथवा





20. *Assertion (A)* : TA and TB are two tangents drawn from an external point T to a circle with centre 'O'. If $\angle TBA = 75^\circ$ then $\angle ABO = 25^\circ$.

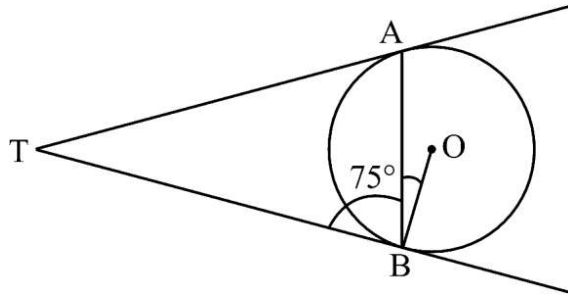

Reason (R) : The tangent drawn at any point of a circle is perpendicular to the radius through the point of contact.

SECTION B

This section comprises *Very Short Answer (VSA)* type questions of 2 marks each. $5 \times 2 = 10$

21. (a) A chord is subtending an angle of 90° at the centre of a circle of radius 14 cm. Find the area of the corresponding minor segment of the circle.

OR

- (b) Find the area of the shaded region if length of radius of each circle is 7 cm. Each circle touches the other two externally.

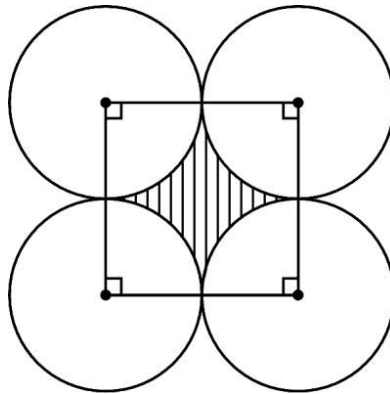

22. Check whether there is any natural number 'n' for which $(14)^n$ ends with the digit '0' or '5'.

23. (a) If $\cos(A + B) = \frac{1}{2}$ and $\tan(A - B) = \frac{1}{\sqrt{3}}$, where $0 \leq A + B \leq 90^\circ$, then find the value of $\sec(2A - 3B)$.

OR





(b) x का मान ज्ञात कीजिए जिसके लिए

$$3 \tan^2 60^\circ - x \sin^2 45^\circ + \frac{3}{4} \sec^2 30^\circ = 2 \operatorname{cosec}^2 30^\circ$$

24. दी गई आकृति में, x , y और z एक समकोण त्रिभुज की तीन भुजाओं को दर्शाते हैं, जहाँ z त्रिभुज का विकर्ण है। सिद्ध कीजिए कि वृत्त, जो त्रिभुज की तीनों भुजाओं को स्पर्श करता है, की

त्रिज्या $r = \frac{x + y - z}{2}$ है।

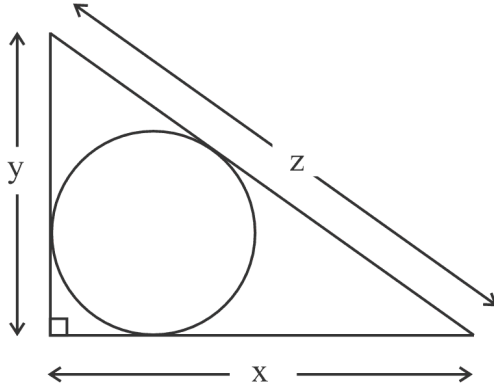

25. PQRS एक समलंब है जिसमें $PQ \parallel SR$ है। यदि असमांतर भुजाओं PS और QR पर क्रमशः दो बिंदु M और N इस प्रकार स्थित हैं कि भुजा MN, भुजा PQ के समांतर है, तो दर्शाइए कि

$$\frac{PM}{MS} = \frac{QN}{NR}$$

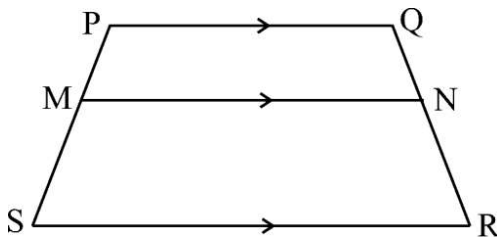

खण्ड ग

इस खण्ड में लघु-उत्तरीय (SA) प्रकार के प्रश्न हैं, जिनमें प्रत्येक के 3 अंक हैं।

6×3=18

26. (a) यदि एक वृत्त के परिगत एक षट्भुज PQRSTU खींचा गया है, तो सिद्ध कीजिए कि

$$PQ + RS + TU = QR + ST + UP$$

अथवा



(b) Find the value of x such that,

$$3 \tan^2 60^\circ - x \sin^2 45^\circ + \frac{3}{4} \sec^2 30^\circ = 2 \operatorname{cosec}^2 30^\circ$$

24. In the given figure, x , y and z are the sides of a right triangle, where z is the hypotenuse. Prove that the radius r of the circle which touches the sides of the triangle is given by $r = \frac{x + y - z}{2}$.

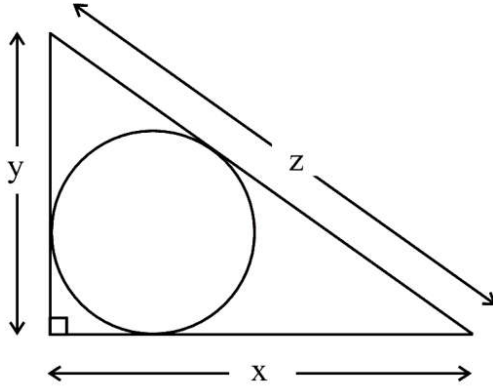

25. PQRS is a trapezium with $PQ \parallel SR$. If M and N are two points on the non-parallel sides PS and QR respectively, such that MN is parallel to PQ , then show that $\frac{PM}{MS} = \frac{QN}{NR}$.

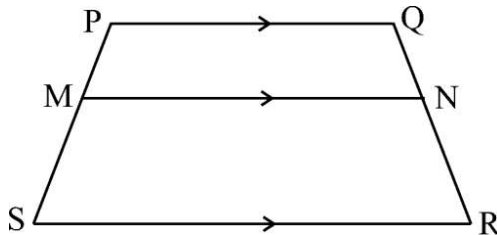

SECTION C

This section comprises Short Answer (SA) type questions of 3 marks each.

$6 \times 3 = 18$

26. (a) If a hexagon PQRSTU circumscribes a circle, prove that,

$$PQ + RS + TU = QR + ST + UP$$

OR





- (b) दी गई आकृति में, त्रिज्या 3 cm और त्रिज्या 5 cm के दो संकेंद्रीय वृत्त बने हैं। एक बाह्य बिन्दु T से इन वृत्तों पर दो स्पर्श-रेखाएँ TR और TP इस प्रकार खींची गई हैं कि TR आंतरिक वृत्त को बिंदु R पर स्पर्श करती है, तथा TP बाहरी वृत्त को बिंदु P पर स्पर्श करती है। यदि $TR = 4\sqrt{10}$ cm है, तो TP की लंबाई ज्ञात कीजिए।

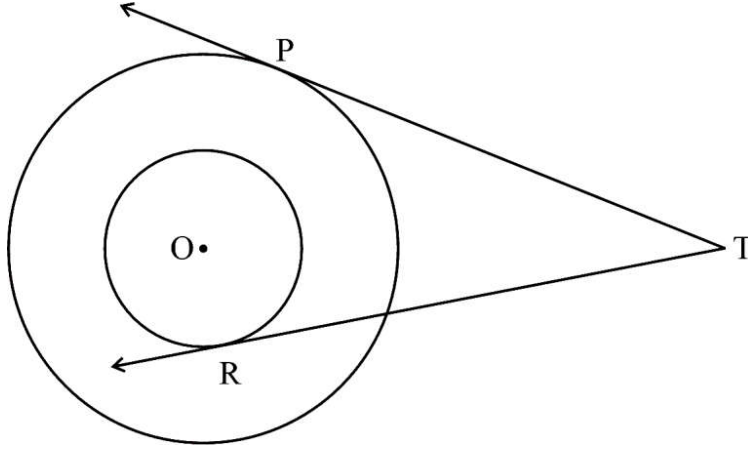

27. सिद्ध कीजिए कि :

$$\left(\tan \alpha + \frac{1}{\cos \alpha} \right)^2 + \left(\tan \alpha - \frac{1}{\cos \alpha} \right)^2 = 2 \left(\frac{1 + \sin^2 \alpha}{1 - \sin^2 \alpha} \right)$$

28. एक रेल दुर्घटना के उपरांत सरकार ने 100 व्यक्तियों को बचाया। उनकी आयु का ब्यौरा निम्न सारणी में अंकित किया गया था। उनकी माध्य आयु ज्ञात कीजिए।

आयु (वर्षों में)	बचाए गए व्यक्तियों की संख्या
10 – 20	9
20 – 30	14
30 – 40	15
40 – 50	21
50 – 60	23
60 – 70	12
70 – 80	6

29. यदि α, β बहुपद $3x^2 - 13x - 10$ के शून्यक हैं, तो $(3\alpha + 1)(3\beta + 1)$ का मान ज्ञात कीजिए।



- (b) In the given figure, two concentric circles have radii 3 cm and 5 cm. Two tangents TR and TP are drawn to the circles from an external point T such that TR touches the inner circle at R and TP touches the outer circle at P. If $TR = 4\sqrt{10}$ cm, then find the length of TP.

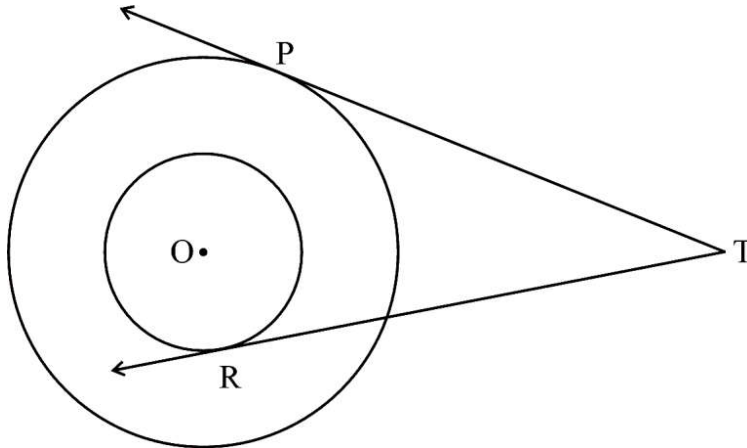

27. Prove that :

$$\left(\tan \alpha + \frac{1}{\cos \alpha} \right)^2 + \left(\tan \alpha - \frac{1}{\cos \alpha} \right)^2 = 2 \left(\frac{1 + \sin^2 \alpha}{1 - \sin^2 \alpha} \right)$$

28. The government rescued 100 people after a train accident. Their ages were recorded in the following table. Find their mean age.

Age (in years)	Number of people rescued
10 – 20	9
20 – 30	14
30 – 40	15
40 – 50	21
50 – 60	23
60 – 70	12
70 – 80	6

29. If α, β are the zeroes of the polynomial $3x^2 - 13x - 10$, then find the value of $(3\alpha + 1)(3\beta + 1)$.





30. एक विज्ञान कार्यशाला में भाग लेने के लिए एक स्कूल ने 42 गणित के शिक्षक, 56 भौतिकी के शिक्षक और 70 रसायन विज्ञान के शिक्षकों को आमंत्रित किया। यदि प्रत्येक मेज़ पर बैठने वाले शिक्षकों की संख्या समान हो और प्रत्येक मेज़ पर एक ही विषय के शिक्षकों को बैठना हो, तो कम-से-कम कितनी मेज़ों की आवश्यकता होगी, ज्ञात कीजिए।

31. (a) एक 2-अंकीय संख्या के अंकों का योगफल 12 है। इस संख्या का 7 गुना, संख्या के अंकों को पलटने से बनी संख्या के 4 गुने के समान है। संख्या ज्ञात कीजिए।

अथवा

(b) निम्न रैखिक समीकरणों के युग्म में x और y के मान ज्ञात कीजिए :

$$62x + 43y = 167$$

$$43x + 62y = 148$$

खण्ड घ

इस खण्ड में दीर्घ-उत्तरीय (LA) प्रकार के प्रश्न हैं, जिनमें प्रत्येक के 5 अंक हैं।

$4 \times 5 = 20$

32. (a) यदि निधि अपनी वास्तविक उम्र से 7 वर्ष छोटी होती, तो उसकी उम्र (वर्षों में) का वर्ग उसकी वास्तविक उम्र के 5 गुना से 1 अधिक होता। उसकी वास्तविक उम्र क्या है ?

अथवा

(b) एक दुकानदार ₹ 1,800 में कुछ पुस्तकें खरीदता है। यदि वह इसी राशि से 15 पुस्तकें अधिक खरीदता, तो उसे प्रत्येक पुस्तक ₹ 20 कम की पड़ती। ज्ञात कीजिए कि उसने कुल कितनी पुस्तकें प्रारम्भ में खरीदी थीं।

33. निम्नलिखित तालिका में एक फुटबॉल मैच के 200 दर्शकों की माध्यक आयु 32 है। लुप्त बारंबारताएँ p और q ज्ञात कीजिए।

आयु (वर्षों में)	दर्शकों की संख्या
0 – 10	20
10 – 20	p
20 – 30	50
30 – 40	60
40 – 50	32
50 – 60	q



30. A school has invited 42 Mathematics teachers, 56 Physics teachers and 70 Chemistry teachers to attend a Science workshop. Find the minimum number of tables required, if the same number of teachers are to sit at a table and each table is occupied by teachers of the same subject.
31. (a) The sum of the digits of a 2-digit number is 12. Seven times the number is equal to four times the number obtained by reversing the order of the digits. Find the number.

OR

- (b) Find the values of x and y from the following pair of linear equations :

$$62x + 43y = 167$$

$$43x + 62y = 148$$

SECTION D

This section comprises Long Answer (LA) type questions of 5 marks each.

$4 \times 5 = 20$

32. (a) If Nidhi were 7 years younger than what she actually is, then the square of her age (in years) would be 1 more than 5 times her actual age. What is her present age ?

OR

- (b) A shopkeeper buys a number of books for ₹ 1,800. If he had bought 15 more books for the same amount, then each book would have cost him ₹ 20 less. Find how many books he bought initially.
33. In the following table, the median age of 200 spectators of a football match is 32. Find the missing frequencies p and q .

Age (in years)	Number of Spectators
0 – 10	20
10 – 20	p
20 – 30	50
30 – 40	60
40 – 50	32
50 – 60	q





34. (a) भुजा 21 cm वाले लकड़ी के एक घनाकार ब्लॉक से बड़े-से-बड़ा एक अर्धगोला खोद कर इस प्रकार निकाला जाता है कि अर्धगोले का आधार, घनाकार ब्लॉक का एक फलक है। ज्ञात कीजिए :

- ब्लॉक में बची लकड़ी का आयतन,
- बचे ठोस का कुल पृष्ठीय क्षेत्रफल।

अथवा

(b) एक ठोस खिलौना एक लम्ब-वृत्तीय शंकु के आकार का है, जो एक अर्धगोले पर अध्यारोपित है। शंकु की त्रिज्या का उसकी तिर्यक ऊँचाई से अनुपात 3 : 5 है। यदि खिलौने का आयतन $240\pi \text{ cm}^3$ है, तो खिलौने की कुल ऊँचाई ज्ञात कीजिए।

35. समलंब PQRS में, $PQ \parallel SR$ और $SR = 2 PQ$ है। PQ के समांतर खींचा गया एक रेखाखंड FE, PS को F पर और QR को E पर प्रतिच्छेद करता है जिससे $\frac{QE}{ER} = \frac{3}{4}$ । विकर्ण QS, FE को बिंदु G पर प्रतिच्छेद करता है। सिद्ध कीजिए कि $\frac{FE}{PQ} = \frac{10}{7}$ ।

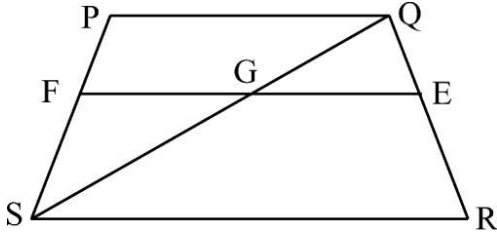

खण्ड ड

इस खण्ड में 3 प्रकरण अध्ययन आधारित प्रश्न हैं जिनमें प्रत्येक के 4 अंक हैं।

$3 \times 4 = 12$

प्रकरण अध्ययन – 1

36. एक स्कूल ने 51वें विश्व पर्यावरण दिवस पर निकटतम पार्क में कुछ संकटापन्न पेड़ लगाने का निर्णय लिया है। उन्होंने उन पेड़ों को कुछ संकेंद्रीय वृत्ताकार पंक्तियों में लगाने का निर्णय लिया है, ताकि प्रत्येक अगली वृत्ताकार पंक्ति में पिछली वृत्ताकार पंक्ति की तुलना में 20 पेड़ अधिक हों। पहली वृत्ताकार पंक्ति में 50 पेड़ लगे हैं।



34. (a) The largest possible hemisphere is drilled out from a wooden cubical block of side 21 cm such that the base of the hemisphere is on one of the faces of the cube. Find :
- (i) the volume of wood left in the block,
 - (ii) the total surface area of the remaining solid.

OR

- (b) A solid toy is in the form of a hemisphere surmounted by a right circular cone. Ratio of the radius of the cone to its slant height is 3 : 5. If the volume of the toy is $240\pi \text{ cm}^3$, then find the total height of the toy.

35. In trapezium PQRS, $PQ \parallel SR$ and $SR = 2 PQ$. A line segment FE drawn parallel to PQ intersects PS at F and QR at E such that $\frac{QE}{ER} = \frac{3}{4}$. Diagonal QS intersects FE at G. Prove that $\frac{FE}{PQ} = \frac{10}{7}$.

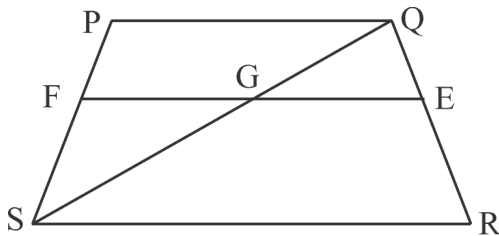

SECTION E

This section comprises 3 case study based questions of 4 marks each.

$3 \times 4 = 12$

Case Study – 1

36. A school has decided to plant some endangered trees on 51st World Environment Day in the nearest park. They have decided to plant those trees in few concentric circular rows such that each succeeding row has 20 more trees than the previous one. The first circular row has 50 trees.





उपर्युक्त दी गई जानकारी के आधार पर, निम्नलिखित प्रश्नों के उत्तर दीजिए :

- (i) 10वीं पंक्ति में कितने पेड़ लगेंगे ? 1
- (ii) 8वीं पंक्ति में, 5वीं पंक्ति से कितने अधिक पेड़ लगेंगे ? 1
- (iii) (a) यदि पार्क में 3200 पेड़ लगाने हों, तो कितनी पंक्तियों की आवश्यकता होगी ? 2
अथवा
- (b) यदि पार्क में 3200 पेड़ लगाने हों, तो 11वीं पंक्ति के पश्चात् कितने पेड़ लगाने के लिए बचे रहेंगे ? 2

प्रकरण अध्ययन – 2

37. पार्थ, एक सॉफ्टवेयर इंजीनियर, अपने काम के सिलसिले में यरूशलम में रहता है। वह शहर के सबसे सुविधाजनक क्षेत्र में रहता है जहाँ से बैंक, अस्पताल, डाकघर और सुपर मार्केट तक आसानी से पहुँचा जा सकता है। ग्राफ़ में, बैंक को $A(9, 5)$ के रूप में, अस्पताल को $B(-3, -1)$ के रूप में तथा सुपर मार्केट को $C(5, -5)$ के रूप में इस प्रकार दर्शाया गया है कि A, B, C एक त्रिभुज बनाते हैं।





Based on the above given information, answer the following questions :

- (i) How many trees will be planted in the 10th row ? 1
- (ii) How many more trees will be planted in the 8th row than in the 5th row ? 1
- (iii) (a) If 3200 trees are to be planted in the park, then how many rows are required ? 2
- OR**
- (b) If 3200 trees are to be planted in the park, then how many trees are still left to be planted after the 11th row ? 2

Case Study – 2

37. Partha, a software engineer, lives in Jerusalem for his work. He lives in the most convenient area of the city from where bank, hospital, post office and supermarket can be easily accessed. In the graph, the bank is plotted as A(9, 5), hospital as B(- 3, - 1) and supermarket as C(5, - 5) such that A, B, C form a triangle.



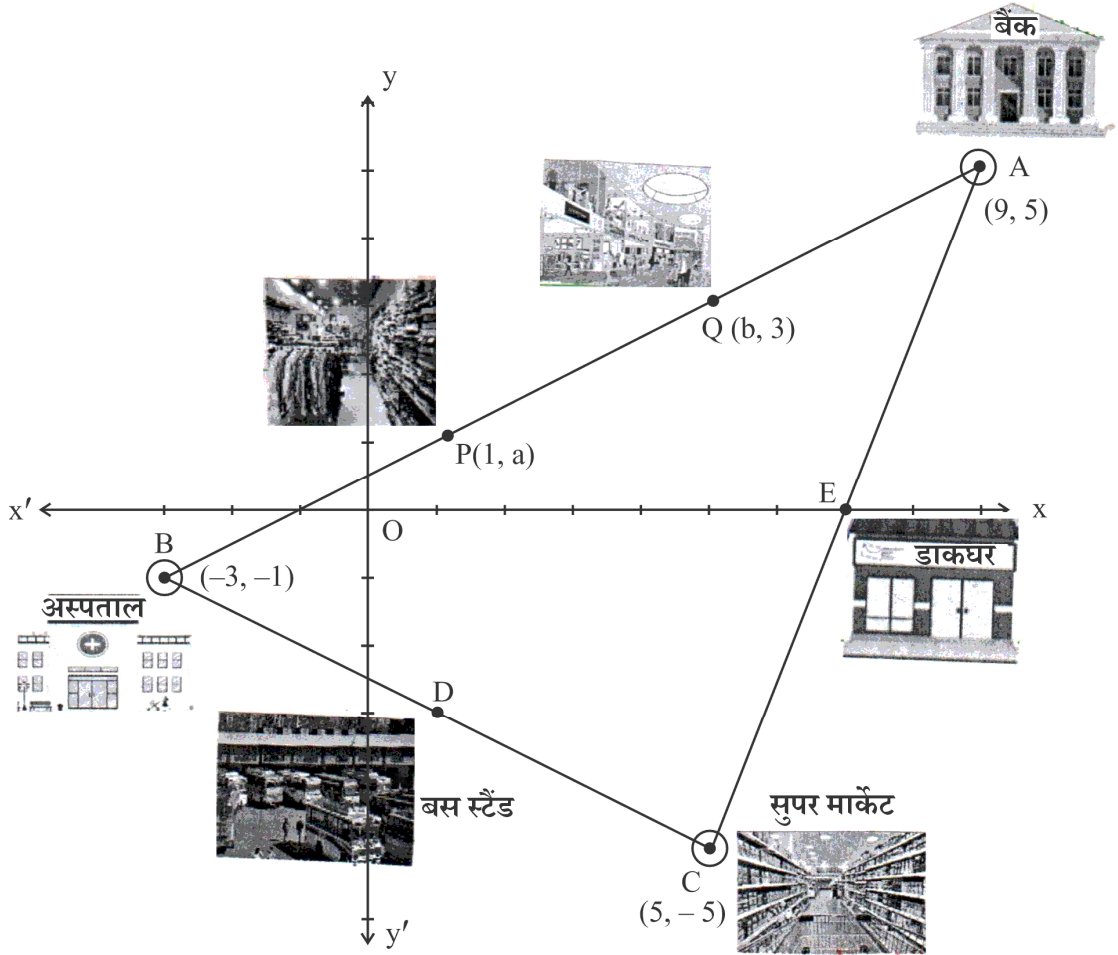

उपर्युक्त दी गई जानकारी के आधार पर, निम्नलिखित प्रश्नों के उत्तर दीजिए :

- (i) बैंक और अस्पताल के बीच की दूरी ज्ञात कीजिए। 1
- (ii) बैंक और सुपर मार्केट के बीच, एक डाकघर E के रूप में दर्शाया गया है जो कि उन दोनों के बीच का मध्य-बिंदु है। E के निर्देशांक ज्ञात कीजिए। 1
- (iii) (a) अस्पताल और सुपर मार्केट के बीच, एक बस स्टैंड है जिसे D के रूप में दर्शाया गया है, जो उन दोनों के बीच का मध्य-बिंदु है। यदि पार्थ बैंक से बस स्टैंड जाना चाहता हो, तो उसको कितनी दूरी तय करने की ज़रूरत होगी? 2

अथवा

- (b) बैंक और अस्पताल के बीच दो विभिन्न वस्त्रों की दुकानें P और Q हैं, जहाँ $BP = PQ = QA$ है। यदि P और Q के निर्देशांक क्रमशः $(1, a)$ तथा $(b, 3)$ हैं, तो 'a' और 'b' के मान ज्ञात कीजिए। 2



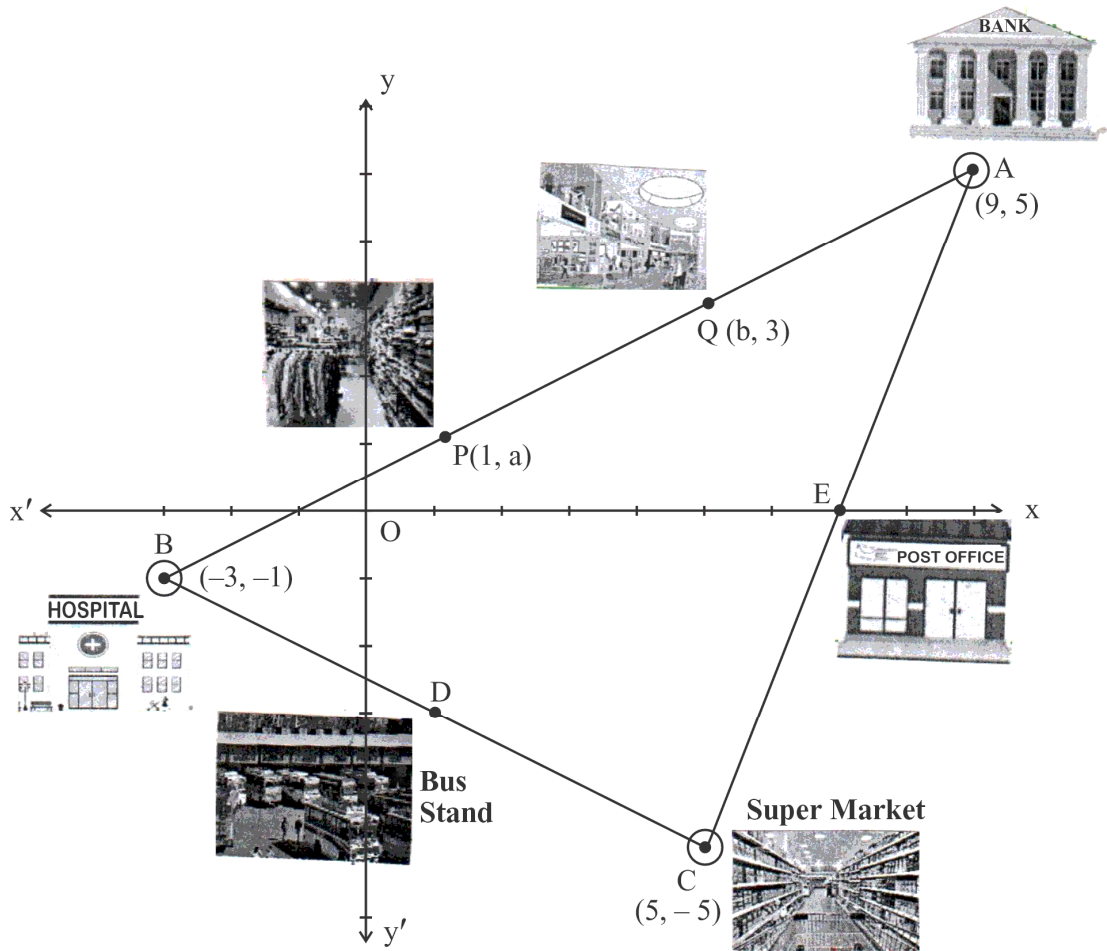

Based on the above given information, answer the following questions :

- (i) Find the distance between the bank and the hospital. 1
- (ii) In between the bank and the supermarket, there is a post office plotted at E which is their mid-point. Find the coordinates of E. 1
- (iii) (a) In between the hospital and the supermarket, there is a bus stop plotted as D, which is their mid-point. If Partha wants to reach the bus stand from the bank, then how much distance does he need to cover ? 2

OR

- (b) P and Q are two different garment shops lying between the bank and the hospital, such that $BP = PQ = QA$. If the coordinates of P and Q are $(1, a)$ and $(b, 3)$ respectively, then find the values of 'a' and 'b'. 2



प्रकरण अध्ययन – 3

38. शॉर्ट सर्किट के कारण, न्यू होम कॉम्प्लेक्स में आग लग गई है। दो इमारतें X तथा Y मुख्य रूप से प्रभावित हुई हैं। दमकल की गाड़ी आ गई है और उसे दोनों इमारतों के बीच तैनात किया गया है। दमकल की गाड़ी के सामने एक बिंदु O पर एक सीढ़ी लगाई जाती है।

क्षैतिज से 60° के कोण पर झुकी हुई सीढ़ी इमारत Y की छत के साथ लगी हुई है। सीढ़ी के पायदान को स्थिर रखा जाता है और कुछ समय बाद इसे बायीं ओर विपरीत इमारत X की छत पर भूमि से 45° के कोण पर झुका दिया जाता है। सीढ़ी का पाद बिंदु 'O' तथा दोनों इमारतों के पाद एक सीधी रेखा में हैं।

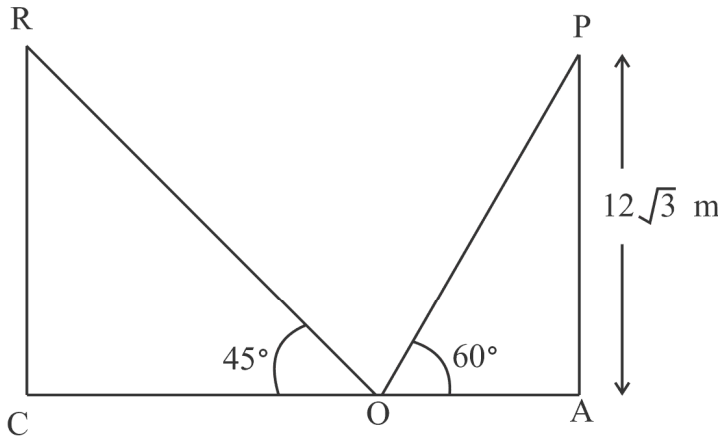

(इमारत X)



(इमारत Y)

उपर्युक्त दी गई जानकारी के आधार पर, निम्नलिखित प्रश्नों के उत्तर दीजिए :

- | | | |
|-------|---|---|
| (i) | सीढ़ी की लंबाई ज्ञात कीजिए। | 1 |
| (ii) | बिंदु 'O' से इमारत Y की दूरी, अर्थात् OA ज्ञात कीजिए। | 1 |
| (iii) | (a) दोनों इमारतों के बीच की क्षैतिज दूरी ज्ञात कीजिए। | 2 |
| | अथवा | |
| | (b) इमारत X की ऊँचाई ज्ञात कीजिए। | 2 |



Case Study – 3

38. Due to short circuit, a fire has broken out in New Home Complex. Two buildings, namely X and Y have mainly been affected. The fire engine has arrived and it has been stationed at a point which is in between the two buildings. A ladder at point O is fixed in front of the fire engine.

The ladder inclined at an angle 60° to the horizontal is leaning against the wall of the terrace (top) of the building Y. The foot of the ladder is kept fixed and after some time it is made to lean against the terrace (top) of the opposite building X at an angle of 45° with the ground. Both the buildings along with the foot of the ladder, fixed at 'O' are in a straight line.

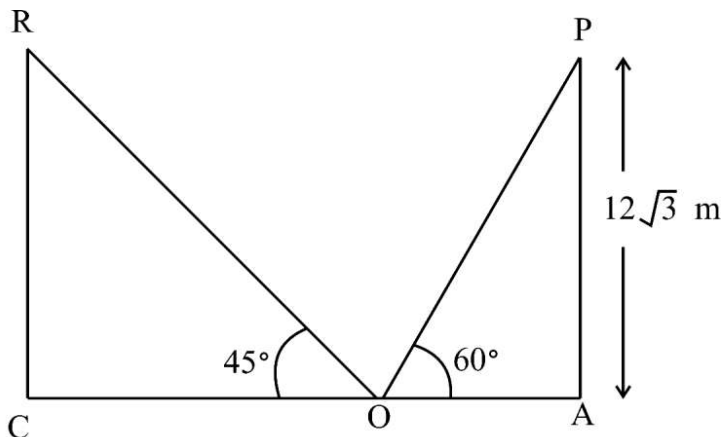

(Building X)



(Building Y)

Based on the above given information, answer the following questions :

- (i) Find the length of the ladder. 1
- (ii) Find the distance of the building Y from point 'O', i.e. OA. 1
- (iii) (a) Find the horizontal distance between the two buildings. 2

OR

- (b) Find the height of the building X. 2

Marking Scheme
Strictly Confidential
(For Internal and Restricted use only)
Secondary School Supplementary Examination, 2024
MATHEMATICS 041 PAPER CODE 30/S/3

General Instructions: -

1	You are aware that evaluation is the most important process in the actual and correct assessment of the candidates. A small mistake in evaluation may lead to serious problems which may affect the future of the candidates, education system and teaching profession. To avoid mistakes, it is requested that before starting evaluation, you must read and understand the spot evaluation guidelines carefully.
2	“Evaluation policy is a confidential policy as it is related to the confidentiality of the examinations conducted, Evaluation done and several other aspects. It’s leakage to public in any manner could lead to derailment of the examination system and affect the life and future of millions of candidates. Sharing this policy/document to anyone, publishing in any magazine and printing in News Paper/Website etc. may invite action under various rules of the Board and IPC.”
3	Evaluation is to be done as per instructions provided in the Marking Scheme. It should not be done according to one’s own interpretation or any other consideration. Marking Scheme should be strictly adhered to and religiously followed. However, while evaluating, answers which are based on latest information or knowledge and/or are innovative, they may be assessed for their correctness otherwise and due marks be awarded to them. In class -X, while evaluating two competency-based questions, please try to understand given answer and even if reply is not from marking scheme but correct competency is enumerated by the candidate, due marks should be awarded.
4	The Marking scheme carries only suggested value points for the answers. These are in the nature of Guidelines only and do not constitute the complete answer. The students can have their own expression and if the expression is correct, the due marks should be awarded accordingly.
5	The Head-Examiner must go through the first five answer books evaluated by each evaluator on the first day, to ensure that evaluation has been carried out as per the instructions given in the Marking Scheme. If there is any variation, the same should be zero after deliberation and discussion. The remaining answer books meant for evaluation shall be given only after ensuring that there is no significant variation in the marking of individual evaluators.
6	Evaluators will mark (✓) wherever answer is correct. For wrong answer CROSS ‘X’ be marked. Evaluators will not put right (✓) while evaluating which gives an impression that answer is correct and no marks are awarded. This is most common mistake which evaluators are committing.
7	If a question has parts, please award marks on the right-hand side for each part. Marks awarded for different parts of the question should then be totalled up and written on the left-hand margin and encircled. This may be followed strictly.
8	If a question does not have any parts, marks must be awarded on the left-hand margin and encircled. This may also be followed strictly.
9	<u>In Q1-Q20, if a candidate attempts the question more than once (without cancelling the previous attempt), marks shall be awarded for the first attempt only and the other answer scored out with a note “Extra Question”.</u>
10	<u>In Q21-Q38, if a student has attempted an extra question, answer of the question deserving more marks should be retained and the other answer scored out with a note “Extra Question”.</u>
11	No marks to be deducted for the cumulative effect of an error. It should be penalized only once.
12	A full scale of marks _____ (example 0 to 80/70/60/50/40/30 marks as given in Question Paper) has to be used. Please do not hesitate to award full marks if the answer deserves it.

13	Every examiner has to necessarily do evaluation work for full working hours i.e., 8 hours every day and evaluate 20 answer books per day in main subjects and 25 answer books per day in other subjects (Details are given in Spot Guidelines). This is in view of the reduced syllabus and number of questions in question paper.
14	<p>Ensure that you do not make the following common types of errors committed by the Examiner in the past:-</p> <ul style="list-style-type: none"> ● Leaving answer or part thereof unassessed in an answer book. ● Giving more marks for an answer than assigned to it. ● Wrong totalling of marks awarded on an answer. ● Wrong transfer of marks from the inside pages of the answer book to the title page. ● Wrong question wise totalling on the title page. ● Wrong totalling of marks of the two columns on the title page. ● Wrong grand total. ● Marks in words and figures not tallying/not same. ● Wrong transfer of marks from the answer book to online award list. ● Answers marked as correct, but marks not awarded. (Ensure that the right tick mark is correctly and clearly indicated. It should merely be a line. Same is with the X for incorrect answer.) <p>Half or a part of answer marked correct and the rest as wrong, but no marks awarded.</p>
15	While evaluating the answer books if the answer is found to be totally incorrect, it should be marked as cross (X) and awarded zero (0) Marks.
16	Any un assessed portion, non-carrying over of marks to the title page, or totalling error detected by the candidate shall damage the prestige of all the personnel engaged in the evaluation work as also of the Board. Hence, in order to uphold the prestige of all concerned, it is again reiterated that the instructions be followed meticulously and judiciously.
17	The Examiners should acquaint themselves with the guidelines given in the “ Guidelines for spot Evaluation ” before starting the actual evaluation.
18	Every Examiner shall also ensure that all the answers are evaluated, marks carried over to the title page, correctly totalled and written in figures and words.
19	The candidates are entitled to obtain photocopy of the Answer Book on request on payment of the prescribed processing fee. All Examiners/Additional Head Examiners/Head Examiners are once again reminded that they must ensure that evaluation is carried out strictly as per value points for each answer as given in the Marking Scheme.



MARKING SCHEME
MATHEMATICS (Subject Code-041)
(PAPER CODE: 30/S/3)

Q. No.	EXPECTED OUTCOMES/VALUE POINTS	Marks
SECTION A		
This section comprises Multiple Choice Questions (MCQs) 1 mark each.		
1	<p>If the length of the shadow on the ground of a pole is $\sqrt{3}$ times the height of the pole, then the angle of elevation of the Sun is :</p> <p>(A) 30° (B) 45° (C) 60° (D) 90°</p>	
Sol.	(A) 30°	1
2	<p>Two dice are thrown at the same time and the product of the numbers appearing on them is noted. The probability that the product of the numbers lies between 8 and 13 is :</p> <p>(A) $\frac{7}{36}$ (B) $\frac{5}{36}$ (C) $\frac{2}{9}$ (D) $\frac{1}{4}$</p>	
Sol.	(A) $\frac{7}{36}$	1
3	<p>If $(k, 3)$ is the point of intersection of the lines represented by $x + py = 6$ and $x = 15$, then (k, p) will be :</p> <p>(A) $(15, 3)$ (B) $(15, -3)$ (C) $(3, 15)$ (D) $(-15, 3)$</p>	
Sol.	(B) $(15, -3)$	1
4	<p>The point on x-axis which is equidistant from the points $(5, -3)$ and $(4, 2)$ is :</p> <p>(A) $(4.5, 0)$ (B) $(7, 0)$ (C) $(0.5, 0)$ (D) $(-7, 0)$</p>	
Sol.	(B) $(7, 0)$	1
5	<p>If $x = 5$ is a solution of the quadratic equation $2x^2 + (k - 1)x + 10 = 0$, then the value of k is :</p> <p>(A) 11 (B) -11 (C) 13 (D) -13</p>	
Sol.	(B) -11	1

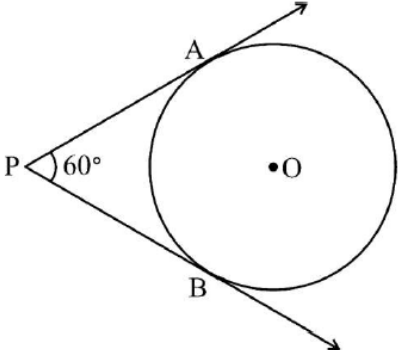

<p>10</p>	<p>The diagonals of a rhombus ABCD intersect at O. Taking 'O' as the centre, an arc of radius 6 cm is drawn intersecting OA and OD at E and F respectively. The area of the sector OEF is :</p> <p>(A) $9\pi \text{ cm}^2$ (B) $3\pi \text{ cm}^2$ (C) $12\pi \text{ cm}^2$ (D) $18\pi \text{ cm}^2$</p>	
<p>Sol.</p>	<p>(A) $9\pi \text{ cm}^2$</p>	<p>1</p>
<p>11</p>	<p>Two A.P.s have the same first term. The common difference of the first A.P. is -3 and of the second A.P. is -5. The difference of the 6th term of the second A.P. from that of the first A.P. is :</p> <p>(A) 2 (B) -8 (C) -10 (D) 10</p>	
<p>Sol.</p>	<p>(D) 10</p>	<p>1</p>
<p>12</p>	<p>The probability of getting a chocolate flavoured ice cream at random, in a lot of 600 ice creams is 0.055. The number of chocolate flavoured ice creams in the lot is :</p> <p>(A) 33 (B) 55 (C) 11 (D) 44</p>	
<p>Sol.</p>	<p>(A) 33</p>	<p>1</p>
<p>13</p>	<p>In the given figure, PA and PB are two tangents drawn to the circle with centre O and radius 5 cm. If $\angle APB = 60^\circ$, then the length of PA is :</p>  <p>(A) $\frac{5}{\sqrt{3}} \text{ cm}$ (B) $5\sqrt{3} \text{ cm}$ (C) $\frac{10}{\sqrt{3}} \text{ cm}$ (D) 10 cm</p>	
<p>Sol.</p>	<p>(B) $5\sqrt{3} \text{ cm}$</p>	<p>1</p>

14	If $5 \tan \theta = 2$, then the value of $\frac{10 \sin \theta - 2 \cos \theta}{5 \sin \theta + 3 \cos \theta}$ is : (A) $\frac{2}{5}$ (B) $\frac{5}{2}$ (C) 1 (D) $\frac{46}{31}$	
Sol.	(A) $\frac{2}{5}$	1
15	All queens, jacks and aces are removed from a pack of 52 playing cards. The remaining cards are well-shuffled and one card is picked up at random from it. The probability of that card to be a king is : (A) $\frac{1}{10}$ (B) $\frac{1}{13}$ (C) $\frac{3}{10}$ (D) $\frac{3}{13}$	
Sol.	(A) $\frac{1}{10}$	1
16	If the sector of a circle with diameter 14 cm makes an angle 90° at the centre, then the perimeter of the sector is : (A) 25 cm (B) 11 cm (C) 36 cm (D) 22 cm	
Sol.	(A) 25 cm	1
17	The value of $\left(\sin^2 \theta + \frac{1}{1 + \tan^2 \theta} \right)$ is : (A) 0 (B) 2 (C) 1 (D) -1	
Sol.	(C) 1	1
18	A cap is cylindrical in shape, surmounted by a conical top. If the volume of the cylindrical part is equal to that of the conical part, then the ratio of the height of the cylindrical part to the height of the conical part is : (A) 1 : 2 (B) 1 : 3 (C) 2 : 1 (D) 3 : 1	
Sol.	(B) 1 : 3	1

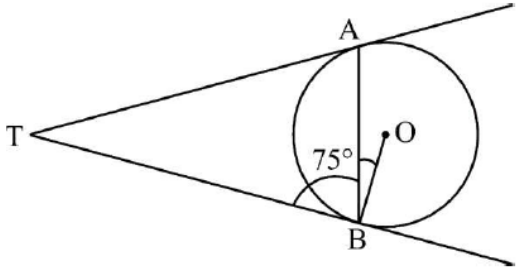

	<p>Directions : In Question 19 and 20, Assertion (A) and Reason (R) are given. Select the correct option from the following :</p> <p>(A) Both Assertion (A) and Reason (R) are true. Reason (R) is the correct explanation of Assertion (A).</p> <p>(B) Both Assertion (A) and Reason (R) are true. Reason (R) does not give correct explanation of (A).</p> <p>(C) Assertion (A) is true but Reason (R) is not true.</p> <p>(D) Assertion (A) is not true but Reason (R) is true.</p>	
19	<p><i>Assertion (A) :</i> If the graph of a polynomial intersects the x-axis at exactly two points, then the number of zeroes of that polynomial is 2.</p> <p><i>Reason (R) :</i> The number of zeroes of a polynomial is equal to the number of points where the graph of the polynomial intersects x-axis.</p>	
Sol.	(A) Both Assertion (A) and Reason (R) are true. Reason (R) is the correct explanation of Assertion (A)	1
20	<p><i>Assertion (A) :</i> TA and TB are two tangents drawn from an external point T to a circle with centre 'O'. If $\angle TBA = 75^\circ$ then $\angle ABO = 25^\circ$.</p>  <p><i>Reason (R) :</i> The tangent drawn at any point of a circle is perpendicular to the radius through the point of contact.</p>	
Sol.	(D) Assertion (A) is not true but Reason (R) is true.	1
	SECTION B	
	This section comprises of Very Short Answer (VSA) type questions of 2 marks each.	
21(a)	A chord is subtending an angle of 90° at the centre of a circle of radius 14 cm. Find the area of the corresponding minor segment of the circle.	
Sol.	$\text{Area of minor segment} = \pi \times 14^2 \times \frac{1}{4} - \frac{1}{2} \times 14^2$ $= (154 - 98) = 56$ <p>Hence, area of minor segment = 56 cm^2</p>	1 1
	OR	

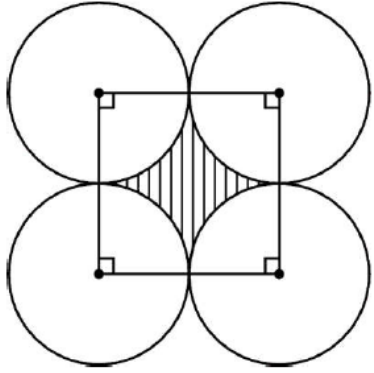

21(b)	<p>Find the area of the shaded region if length of radius of each circle is 7 cm.</p> <p>Each circle touches the other two externally.</p> 	
Sol.	<p>Side of square = 14 cm</p> <p>Area of shaded region = area of square – area of 4 quadrants</p> $= 14^2 - 4 \times \frac{22}{7} \times 7^2 \times \frac{90}{360}$ $= (196 - 154) = 42$ <p>Hence, area of shaded region = 42 cm²</p>	<p>1/2</p> <p>1</p> <p>1/2</p>
22	<p>Check whether there is any natural number 'n' for which (14)ⁿ ends with the digit '0' or '5'.</p>	
Sol.	<p>(14)ⁿ = 2ⁿ7ⁿ</p> <p>as it does not have 5 as the prime factor</p> <p>Hence, it cannot end with the digit 0 or 5</p>	<p>1</p> <p>1</p>
23(a)	<p>If $\cos(A + B) = \frac{1}{2}$ and $\tan(A - B) = \frac{1}{\sqrt{3}}$, where $0 \leq A + B \leq 90^\circ$, then find the value of $\sec(2A - 3B)$.</p>	
Sol.	<p>$\cos(A + B) = \frac{1}{2} \Rightarrow A + B = 60^\circ \dots (i)$</p> <p>$\tan(A - B) = \frac{1}{\sqrt{3}} \Rightarrow A - B = 30^\circ \dots (ii)$</p> <p>Solving (i) and (ii), we get $A = 45^\circ$ and $B = 15^\circ$</p> <p>$\Rightarrow \sec(2A - 3B) = \sec(90^\circ - 45^\circ)$</p> $= \sec 45^\circ = \sqrt{2}$	<p>1/2</p> <p>1/2</p> <p>1/2</p> <p>1/2</p>
OR		
23(b)	<p>Find the value of x such that,</p> $3 \tan^2 60^\circ - x \sin^2 45^\circ + \frac{3}{4} \sec^2 30^\circ = 2 \operatorname{cosec}^2 30^\circ$	
Sol.	$3 \tan^2 60^\circ - x \sin^2 45^\circ + \frac{3}{4} \sec^2 30^\circ = 2 \operatorname{cosec}^2 30^\circ$ $\Rightarrow 3(\sqrt{3})^2 - x\left(\frac{1}{\sqrt{2}}\right)^2 + \frac{3}{4}\left(\frac{2}{\sqrt{3}}\right)^2 = 2(2)^2$ $\Rightarrow 9 - \frac{x}{2} + 1 = 8$ $\Rightarrow x = 4$	<p>1</p> <p>1</p>

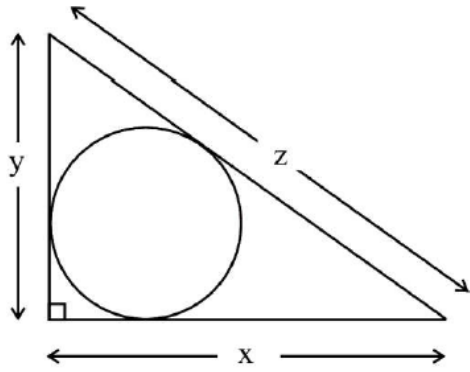
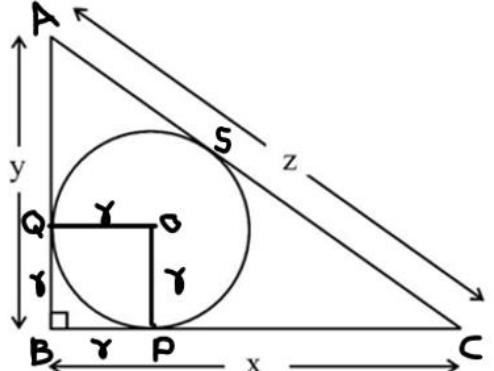
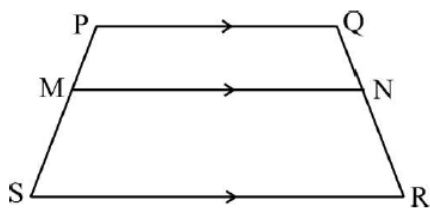
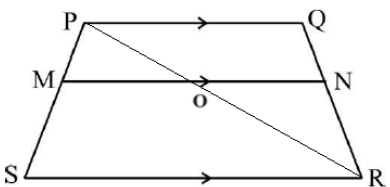
<p>24</p>	<p>In the given figure, x, y and z are the sides of a right triangle, where z is the hypotenuse. Prove that the radius r of the circle which touches the sides of the triangle is given by $r = \frac{x + y - z}{2}$.</p> 	
<p>Sol.</p>	 <p>Clearly OQBP is a square $OP = OQ = QB = BP = r$ $CS = PC = x - r$ $AS = AQ = y - r$ $AC = z = AS + CS = x - r + y - r$ Gives $r = \frac{x + y - z}{2}$</p>	<p>$\frac{1}{2}$</p> <p>$\frac{1}{2}$</p> <p>$\frac{1}{2}$</p> <p>$\frac{1}{2}$</p>
<p>25</p>	<p>PQRS is a trapezium with $PQ \parallel SR$. If M and N are two points on the non-parallel sides PS and QR respectively, such that MN is parallel to PQ, then show that $\frac{PM}{MS} = \frac{QN}{NR}$.</p> 	
<p>Sol.</p>	<p>Join PR</p> 	<p>$\frac{1}{2}$</p>

	$PQ \parallel SR$ and $MN \parallel PQ \Rightarrow MN \parallel SR$ In ΔPSR , $\frac{PM}{MS} = \frac{PO}{OR} \quad \dots (i)$ In ΔPQR , $\frac{PO}{OR} = \frac{QN}{NR} \quad \dots (ii)$ From (i) and (ii), $\frac{PM}{MS} = \frac{QN}{NR}$	$\frac{1}{2}$ $\frac{1}{2}$ $\frac{1}{2}$
--	--	---

SECTION C

This section comprises of Short Answer (SA) type questions of 3 marks each.

26(a)	If a hexagon PQRSTU circumscribes a circle, prove that, $PQ + RS + TU = QR + ST + UP$	
--------------	--	--

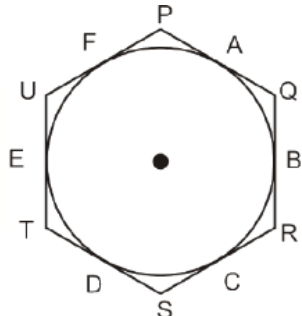
Sol.	 <p>In the given figure, $PA = PF \dots (1)$ $AQ = BQ \dots (2)$ $RC = RB \dots (3)$ $CS = DS \dots (4)$ $ET = TD \dots (5)$ $UE = UF \dots (6)$ Adding (1), (2),(3), (4), (5) and (6), $PA + AQ + RC + CS + ET + UE = PF + BQ + BR + DS + TD + UF$ $\Rightarrow PQ + RS + TU = UP + ST + QR$</p>	<p align="center">Correct figure</p> <p align="right">1</p> <p align="right">$\frac{1}{2}$</p> <p align="right">$\frac{1}{2}$</p>
-------------	---	--

OR

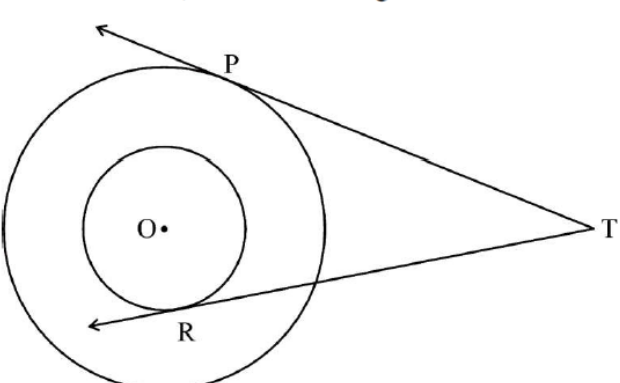
26(b)	<p>In the given figure, two concentric circles have radii 3 cm and 5 cm. Two tangents TR and TP are drawn to the circles from an external point T such that TR touches the inner circle at R and TP touches the outer circle at P. If $TR = 4\sqrt{10}$ cm, then find the length of TP.</p> 	
--------------	--	--

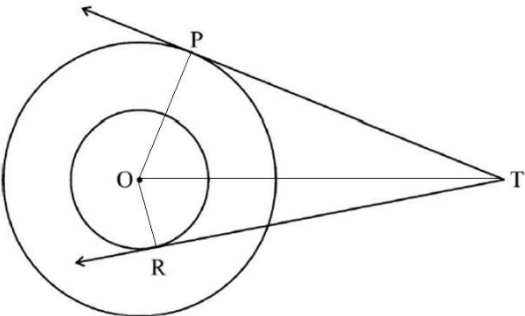
<p>Sol.</p>	 <p>Join OR, OP and OT In ΔORT, $OT^2 = OR^2 + TR^2 = 3^2 + (4\sqrt{10})^2 = 169$ $\therefore OT = 13$ cm In ΔOPT, $TP^2 = OT^2 - OP^2 = 13^2 - 5^2 = 144$ $\therefore TP = 12$ cm</p>	<p>1</p> <p>1</p> <p>1</p>																
<p>27</p>	<p>Prove that :</p> $\left(\tan \alpha + \frac{1}{\cos \alpha} \right)^2 + \left(\tan \alpha - \frac{1}{\cos \alpha} \right)^2 = 2 \left(\frac{1 + \sin^2 \alpha}{1 - \sin^2 \alpha} \right)$																	
<p>Sol.</p>	$\begin{aligned} \text{LHS} &= \left(\frac{\sin \alpha}{\cos \alpha} + \frac{1}{\cos \alpha} \right)^2 + \left(\frac{\sin \alpha}{\cos \alpha} - \frac{1}{\cos \alpha} \right)^2 \\ &= \left(\frac{\sin \alpha + 1}{\cos \alpha} \right)^2 + \left(\frac{\sin \alpha - 1}{\cos \alpha} \right)^2 \\ &= \frac{\sin^2 \alpha + 2 \sin \alpha + 1 + \sin^2 \alpha - 2 \sin \alpha + 1}{1 - \sin^2 \alpha} \\ &= \frac{2(1 + \sin^2 \alpha)}{1 - \sin^2 \alpha} = \text{RHS} \end{aligned}$	<p>1</p> <p>$\frac{1}{2}$</p> <p>1</p> <p>$\frac{1}{2}$</p>																
<p>28</p>	<p>The government rescued 100 people after a train accident. Their ages were recorded in the following table. Find their mean age.</p> <table border="1" data-bbox="375 1366 917 1792"> <thead> <tr> <th>Age (in years)</th> <th>Number of people rescued</th> </tr> </thead> <tbody> <tr> <td>10 – 20</td> <td>9</td> </tr> <tr> <td>20 – 30</td> <td>14</td> </tr> <tr> <td>30 – 40</td> <td>15</td> </tr> <tr> <td>40 – 50</td> <td>21</td> </tr> <tr> <td>50 – 60</td> <td>23</td> </tr> <tr> <td>60 – 70</td> <td>12</td> </tr> <tr> <td>70 – 80</td> <td>6</td> </tr> </tbody> </table>	Age (in years)	Number of people rescued	10 – 20	9	20 – 30	14	30 – 40	15	40 – 50	21	50 – 60	23	60 – 70	12	70 – 80	6	
Age (in years)	Number of people rescued																	
10 – 20	9																	
20 – 30	14																	
30 – 40	15																	
40 – 50	21																	
50 – 60	23																	
60 – 70	12																	
70 – 80	6																	

Sol.	<table border="1"> <thead> <tr> <th>Age (in years)</th> <th>Number of people rescued (f_i)</th> <th>x_i</th> <th>u_i</th> <th>$f_i u_i$</th> </tr> </thead> <tbody> <tr> <td>10-20</td> <td>9</td> <td>15</td> <td>-3</td> <td>-27</td> </tr> <tr> <td>20-30</td> <td>14</td> <td>25</td> <td>-2</td> <td>-28</td> </tr> <tr> <td>30-40</td> <td>15</td> <td>35</td> <td>-1</td> <td>-15</td> </tr> <tr> <td>40-50</td> <td>21</td> <td>45</td> <td>0</td> <td>0</td> </tr> <tr> <td>50-60</td> <td>23</td> <td>55</td> <td>1</td> <td>23</td> </tr> <tr> <td>60-70</td> <td>12</td> <td>65</td> <td>2</td> <td>24</td> </tr> <tr> <td>70-80</td> <td>6</td> <td>75</td> <td>3</td> <td>18</td> </tr> <tr> <td>Total</td> <td>100</td> <td></td> <td></td> <td>-5</td> </tr> </tbody> </table>	Age (in years)	Number of people rescued (f_i)	x_i	u_i	$f_i u_i$	10-20	9	15	-3	-27	20-30	14	25	-2	-28	30-40	15	35	-1	-15	40-50	21	45	0	0	50-60	23	55	1	23	60-70	12	65	2	24	70-80	6	75	3	18	Total	100			-5	1½ marks for correct table
	Age (in years)	Number of people rescued (f_i)	x_i	u_i	$f_i u_i$																																										
	10-20	9	15	-3	-27																																										
	20-30	14	25	-2	-28																																										
	30-40	15	35	-1	-15																																										
	40-50	21	45	0	0																																										
	50-60	23	55	1	23																																										
	60-70	12	65	2	24																																										
	70-80	6	75	3	18																																										
Total	100			-5																																											
<p>Mean Age = $45 + \frac{(-5)}{100} \times 10$ $= 44.5$ Hence, mean age is 44.5 years</p>	1 ½																																														
29	If α, β are the zeroes of the polynomial $3x^2 - 13x - 10$, then find the value of $(3\alpha + 1)(3\beta + 1)$.																																														
Sol.	α, β are zeroes of $3x^2 - 13x - 10$ $\therefore \alpha + \beta = \frac{13}{3}, \quad \alpha\beta = \frac{-10}{3}$ $(3\alpha + 1)(3\beta + 1) = 9\alpha\beta + 3(\alpha + \beta) + 1$ $= -30 + 13 + 1$ $= -16$	1 ½ 1 ½																																													
30	A school has invited 42 Mathematics teachers, 56 Physics teachers and 70 Chemistry teachers to attend a Science workshop. Find the minimum number of tables required, if the same number of teachers are to sit at a table and each table is occupied by teachers of the same subject.																																														
Sol.	<p>HCF (42, 56, 70) = 14 Minimum number of tables required = $\frac{42}{14} + \frac{56}{14} + \frac{70}{14}$ $= 12$</p>	1½ 1 ½																																													
31(a)	The sum of the digits of a 2-digit number is 12. Seven times the number is equal to four times the number obtained by reversing the order of the digits. Find the number.																																														
Sol.	<p>Let the unit's place digit be x and ten's place digit be y \therefore Number = $10y + x$ According to question, $x + y = 12 \dots(i)$ and $7(10y + x) = 4(10x + y)$ $x - 2y = 0 \dots(ii)$ Solving (i) and (ii), we get</p>	½ ½ 1																																													



	$x = 8$ and $y = 4$ Hence, the required number is 48	$\frac{1}{2}$ $\frac{1}{2}$
OR		
31(b)	Find the values of x and y from the following pair of linear equations : $62x + 43y = 167$ $43x + 62y = 148$	
Sol.	$62x + 43y = 167$... (i) $43x + 62y = 148$... (ii) Adding (i) and (ii) and simplifying, we get $x + y = 3$... (iii) Subtracting (ii) from (i) and simplifying, we get $x - y = 1$... (iv) Solving (iii) and (iv) to get $x = 2$ and $y = 1$	1 1 1
SECTION D This section comprises of Long Answer (LA) type questions of 5 marks each.		
32(a)	If Nidhi were 7 years younger than what she actually is, then the square of her age (in years) would be 1 more than 5 times her actual age. What is her present age ?	
Sol.	Let the present age of Nidhi be x years. According to question, $(x - 7)^2 = 5x + 1$ $\Rightarrow x^2 - 19x + 48 = 0$ $\Rightarrow (x - 16)(x - 3) = 0$ $\Rightarrow x = 16, 3$ $x \neq 3$ $\therefore x = 16$ Hence, the present age of Nidhi = 16 years	2 1 1 1
OR		
32(b)	A shopkeeper buys a number of books for ₹ 1,800. If he had bought 15 more books for the same amount, then each book would have cost him ₹ 20 less. Find how many books he bought initially.	
Sol.	Let the number of books bought initially be x According to question, $\frac{1800}{x} - \frac{1800}{x+15} = 20$ $\Rightarrow x^2 + 15x - 1350 = 0$ $\Rightarrow (x + 45)(x - 30) = 0$ $x \neq -45$ $\therefore x = 30$ So, the number of books bought initially = 30	2 1 1 1



33	In the following table, the median age of 200 spectators of a football match is 32. Find the missing frequencies p and q.	
	Age (in years)	Number of Spectators
	0 – 10	20
	10 – 20	p
	20 – 30	50
	30 – 40	60
	40 – 50	32
	50 – 60	q

Sol.	Age (in years)	Number of consumers	Cumulative frequency	1 mark for correct table
	0 – 10	20	20	
	10 – 20	p	20 + p	
	20 – 30	50	70 + p	
	30 – 40	60	130 + P	
	40 – 50	32	162 + p	
	50 – 60	q	162 + p + q	
	Total	162 + p + q		

$162 + p + q = 200$
 $\Rightarrow p + q = 38 \dots (i)$
 Median = 32 \therefore 30 – 40 is the median class.
 $\Rightarrow 32 = 30 + \frac{(100 - 70 - p)}{60} \times 10$
 Solving, we get $p = 18$
 From (i), $q = 20$

34(a)	<p>The largest possible hemisphere is drilled out from a wooden cubical block of side 21 cm such that the base of the hemisphere is on one of the faces of the cube. Find :</p> <p>(i) the volume of wood left in the block,</p> <p>(ii) the total surface area of the remaining solid.</p>	
--------------	---	--

Sol.	<p>Diameter of hemisphere = side of the cube = 21 cm \therefore radius of hemisphere = $\frac{21}{2}$ cm</p> <p>(i) Volume of the wood left = volume of cube – volume of hemisphere $= 21^3 - \frac{2}{3} \times \frac{22}{7} \times \left(\frac{21}{2}\right)^3$ $= 6835.5 \text{ cm}^3$</p> <p>(ii) Total surface area of remaining solid = TSA of cube – base area of hemisphere + CSA of hemisphere</p>	<p>$\frac{1}{2}$</p> <p>1</p> <p>1</p>
-------------	---	---

$$= 6 \times 21^2 - \frac{22}{7} \times \left(\frac{21}{2}\right)^2 + 2 \times \frac{22}{7} \times \left(\frac{21}{2}\right)^2$$

$$= 2992.5 \text{ cm}^2$$

1½
1

OR

34(b)

A solid toy is in the form of a hemisphere surmounted by a right circular cone. Ratio of the radius of the cone to its slant height is 3 : 5. If the volume of the toy is $240\pi \text{ cm}^3$, then find the total height of the toy.

Sol.

Let the radius and the slant height of the cone be $3x \text{ cm}$ and $5x \text{ cm}$ respectively

$$\therefore \text{height of the cone } (h) = \sqrt{(5x)^2 - (3x)^2} = 4x \text{ cm}$$

According to question, volume of toy = 240π

$$\Rightarrow \frac{2}{3}\pi(3x)^3 + \frac{1}{3}\pi(3x)^2(4x) = 240\pi$$

Solving, we get $x = 2$

$$\therefore \text{Total height of toy} = [4(2) + 3(2)] \text{ cm} = 14 \text{ cm}$$

½
1

1½
1

1

35

In trapezium PQRS, $PQ \parallel SR$ and $SR = 2PQ$. A line segment FE drawn parallel to PQ intersects PS at F and QR at E such that $\frac{QE}{ER} = \frac{3}{4}$. Diagonal QS intersects

FE at G. Prove that $\frac{FE}{PQ} = \frac{10}{7}$.

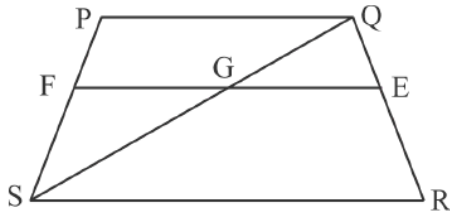

Sol.

$GE \parallel PQ$ and $PQ \parallel SR \Rightarrow GE \parallel SR$

$\therefore \Delta QGE \sim \Delta QSR$

$$\Rightarrow \frac{GE}{SR} = \frac{QE}{QR} = \frac{3}{7}$$

Given, $SR = 2PQ$

$$\Rightarrow \frac{GE}{PQ} = \frac{6}{7} \dots (i)$$

Now, $FG \parallel PQ$

$\therefore \Delta SFG \sim \Delta SPQ$

$$\Rightarrow \frac{FG}{PQ} = \frac{SF}{SP}$$

$$\text{Also, } \frac{SF}{SP} = \frac{RE}{RQ} = \frac{4}{7}$$

$$\Rightarrow \frac{FG}{PQ} = \frac{4}{7} \dots (ii)$$

$$\text{Adding (i) and (ii), } \frac{FE}{PQ} = \frac{6}{7} + \frac{4}{7} = \frac{10}{7}$$

1
½

½

1

1

½

½

SECTION E

This section comprises of 3 case study-based questions of 4 marks each.

<p>36</p>	<p>A school has decided to plant some endangered trees on 51st World Environment Day in the nearest park. They have decided to plant those trees in few concentric circular rows such that each succeeding row has 20 more trees than the previous one. The first circular row has 50 trees.</p>  <p>Based on the above given information, answer the following questions :</p> <p>(i) How many trees will be planted in the 10th row ? 1</p> <p>(ii) How many more trees will be planted in the 8th row than in the 5th row ? 1</p> <p>(iii) (a) If 3200 trees are to be planted in the park, then how many rows are required ? 2</p> <p style="text-align: center;">OR</p> <p>(b) If 3200 trees are to be planted in the park, then how many trees are still left to be planted after the 11th row ? 2</p>	
<p>Sol.</p>	<p>Here $a = 50$ and $d = 20$</p> <p>(i) Number of trees planted in 10th row $= a_{10} = 50 + 9 \times 20$ $= 230$</p> <p>(ii) $a_8 - a_5 = 3 \times 20 = 60$</p> <p>(iii) (a) Let $S_n = 3200$ $\Rightarrow \frac{n}{2} [2 \times 50 + (n - 1) \times 20] = 3200$ $\Rightarrow n^2 + 4n - 320 = 0$ $\Rightarrow (n + 20)(n - 16) = 0$ $n \neq -20$ $\therefore n = 16$ Hence, required number of rows are 16</p> <p style="text-align: center;">OR</p> <p>(iii) (b) Required number of trees $= S_n - S_{11}$ $= 3200 - \frac{11}{2} [2 \times 50 + 10 \times 20]$ $= 1550$</p> <p>Hence, number of trees left are 1550</p>	<p>$\frac{1}{2}$</p> <p>$\frac{1}{2}$</p> <p>1</p> <p>$\frac{1}{2}$</p> <p>$\frac{1}{2}$</p> <p>$\frac{1}{2}$</p> <p>$\frac{1}{2}$</p> <p>$\frac{1}{2}$</p> <p>$\frac{1}{2}$</p> <p>1</p> <p>$\frac{1}{2}$</p>

Partha, a software engineer, lives in Jerusalem for his work. He lives in the most convenient area of the city from where bank, hospital, post office and supermarket can be easily accessed. In the graph, the bank is plotted as A(9, 5), hospital as B(-3, -1) and supermarket as C(5, -5) such that A, B, C form a triangle.

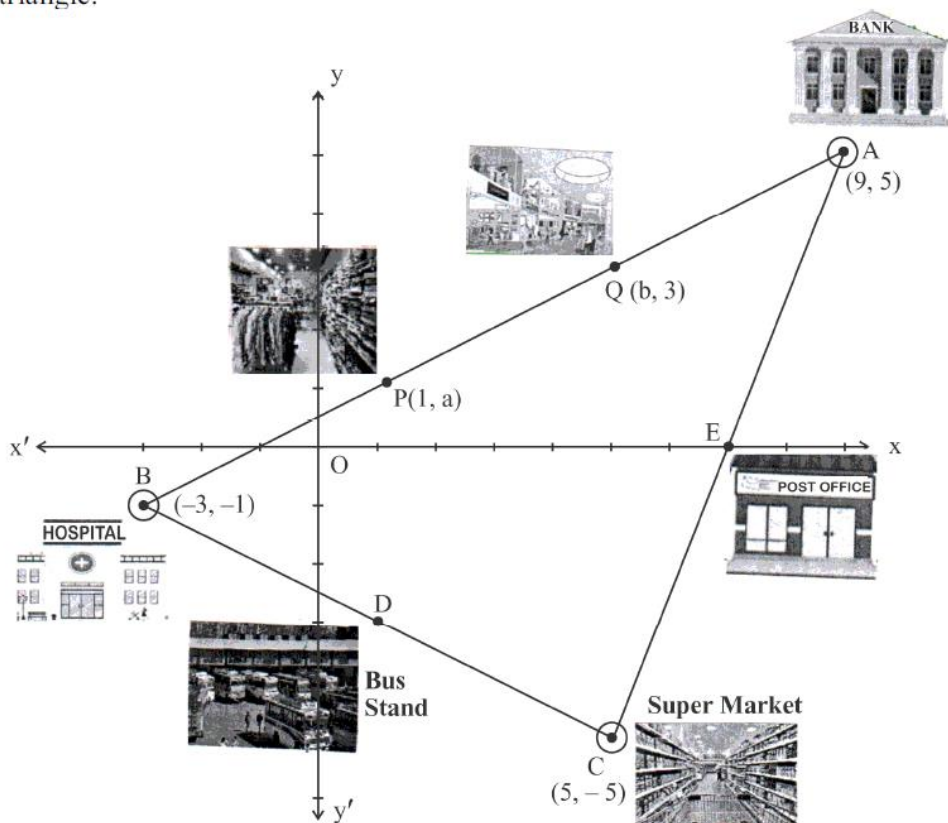

Based on the above given information, answer the following questions :

- (i) Find the distance between the bank and the hospital. 1
- (ii) In between the bank and the supermarket, there is a post office plotted at E which is their mid-point. Find the coordinates of E. 1
- (iii) (a) In between the hospital and the supermarket, there is a bus stop plotted as D, which is their mid-point. If Partha wants to reach the bus stand from the bank, then how much distance does he need to cover? 2
- OR**
- (b) P and Q are two different garment shops lying between the bank and the hospital, such that $BP = PQ = QA$. If the coordinates of P and Q are (1, a) and (b, 3) respectively, then find the values of 'a' and 'b'. 2

Sol.

- (i) Distance between bank and hospital = $\sqrt{(-3-9)^2 + (-1-5)^2}$
 $= \sqrt{180}$ units or $6\sqrt{5}$ units $\frac{1}{2}$
- (ii) Coordinates of E are $\left(\frac{9+5}{2}, \frac{5+(-5)}{2}\right) = (7, 0)$ $\frac{1}{2} + \frac{1}{2}$
- (iii) (a) Coordinates of D are $\left(\frac{-3+5}{2}, \frac{-1+(-5)}{2}\right) = (1, -3)$ **1**
 Distance Partha need to cover = $\sqrt{(9-1)^2 + (5-(-3))^2}$
 $= \sqrt{128}$ units or $8\sqrt{2}$ units $\frac{1}{2}$
- OR**
- (iii) (b) P is mid-point of BQ $\frac{1}{2}$



	$\therefore a = \frac{-1+3}{2} = 1$ <p>Q is mid-point of PA</p> $\therefore b = \frac{1+9}{2} = 5$	1
		1

38	<p>The ladder inclined at an angle 60° to the horizontal is leaning against the wall of the terrace (top) of the building Y. The foot of the ladder is kept fixed and after some time it is made to lean against the terrace (top) of the opposite building X at an angle of 45° with the ground. Both the buildings along with the foot of the ladder, fixed at 'O' are in a straight line.</p> <div style="text-align: center;"> </div> <p style="text-align: center;">(Building X)  (Building Y)</p> <p>Based on the above given information, answer the following questions :</p> <p>(i) Find the length of the ladder. 1</p> <p>(ii) Find the distance of the building Y from point 'O', i.e. OA. 1</p> <p>(iii) (a) Find the horizontal distance between the two buildings. 2</p> <p style="text-align: center;">OR</p> <p>(b) Find the height of the building X. 2</p>	
-----------	--	--

Sol.	<p>(i) In ΔOAP, $\frac{OP}{12\sqrt{3}} = \text{cosec } 60^\circ = \frac{2}{\sqrt{3}}$ $\Rightarrow OP = 24 \text{ m}$ \therefore Length of ladder is 24 m</p> <p>(ii) In ΔOAP, $\frac{OA}{12\sqrt{3}} = \cot 60^\circ = \frac{1}{\sqrt{3}}$ $\Rightarrow OA = 12 \text{ m}$ \therefore the distance of the building Y from point O i.e., OA is 12 m</p> <p>(iii) (a) $OP = OR = 24 \text{ m}$</p>	<p>$\frac{1}{2}$</p> <p>$\frac{1}{2}$</p> <p>$\frac{1}{2}$</p> <p>$\frac{1}{2}$</p> <p>$\frac{1}{2}$</p>
-------------	--	---

	<p>∴ In $\triangle OCR$, $\frac{OC}{24} = \cos 45^\circ = \frac{1}{\sqrt{2}}$ $\Rightarrow OC = 12\sqrt{2}$ m</p> <p>∴ distance between two buildings = $OA + OC$ $= (12 + 12\sqrt{2})$ m or $12(1 + \sqrt{2})$ m</p> <p style="text-align: center;">OR</p> <p>(iii) (b) $OP = OR = 24$ m</p> <p>∴ In $\triangle OCR$, $\frac{RC}{24} = \sin 45^\circ = \frac{1}{\sqrt{2}}$ $\Rightarrow RC = 12\sqrt{2}$ m</p> <p>∴ height of building X is $12\sqrt{2}$ m</p>	<p style="text-align: center;">1</p> <p style="text-align: center;">$\frac{1}{2}$</p> <p style="text-align: center;">$\frac{1}{2}$</p> <p style="text-align: center;">1</p> <p style="text-align: center;">$\frac{1}{2}$</p>
--	--	---